

# Snubber Capacitor (Metallised Polypropylene Film Capacitors)

PCPW 235  
MKP

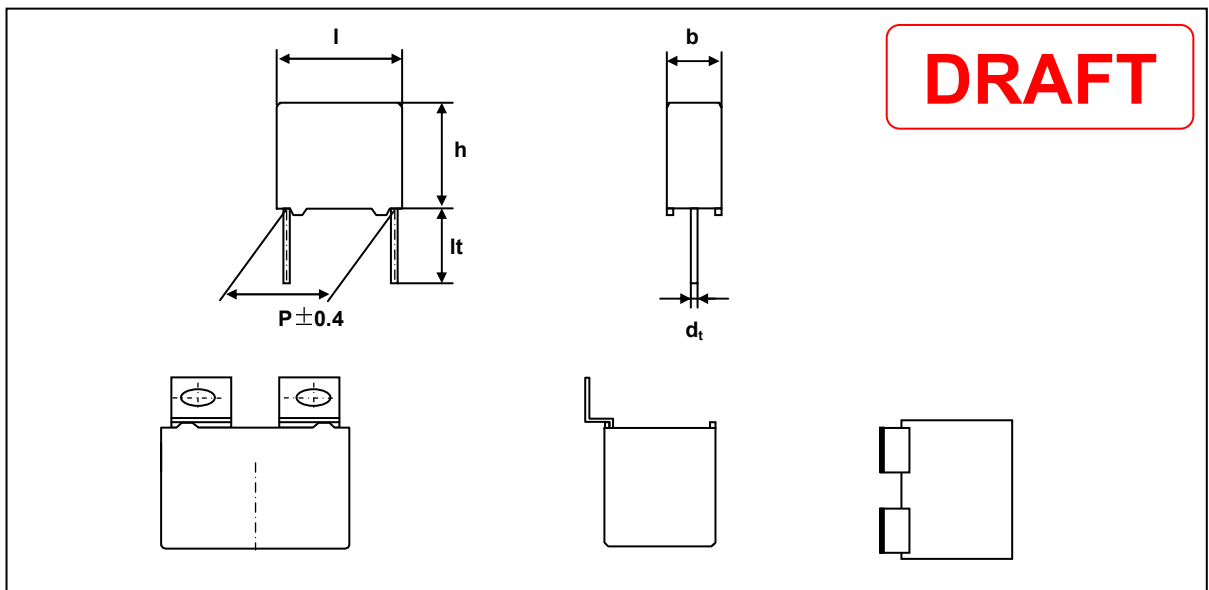

## QUICK REFERENCE DATA

Capacitance range	0.47 to 2.2 $\mu\text{F}$
Capacitance tolerance	$\pm 5\%$ , $\pm 10\%$ ,
Rated voltage (DC)	850V, 1000V, 1250V,
Max. repetitive peak voltage ( $V_{pkr}$ )	$1.15 \times V_R$ (max. 30min. within one day)
Max. non-repetitive peak current ( $I_{pk}$ )	$1.15 \times I_{pk}$
Dissipation factor (DF)	0.0005 at 1KHz ( $C \leq 5\mu\text{F}$ ), 0.0008 at 1KHz ( $5\mu\text{F} < C \leq 25\mu\text{F}$ )
Insulation resistance (IR)	30,000s after 1minute of electrification at 500Vdc ( $V_{Rdc} \geq 500\text{Vdc}$ )
Climatic category	40 / 85 / 56 according to IEC 60068-1
Temperature range	$-40^\circ\text{C} \sim +85^\circ\text{C}$
Max permissible ambient temperature	$85^\circ\text{C}$ (operation at rated power, rated current and natural cooling)
Life time expectancy	$> 40,000$ hours at $V_R$ , $85^\circ\text{C}$
Potting & Encapsulation material	Qualified in accordance with UL94V-0

FEATURES	APPLICATIONS
<ul style="list-style-type: none"> <li>- Self-Healing</li> <li>- Low contact resistance</li> <li>- Low loss dielectric</li> <li>- High ripple current</li> <li>- High contact reliability</li> </ul>	<ul style="list-style-type: none"> <li>. Snubber Capacitor for IGBT</li> <li>.</li> </ul>

- Please refer to caution and warning at <http://www.pilkor.co.kr/download/Introductions.pdf> before using these products.

# Snubbrer Capacitor (Metallised Polypropylene Film Capacitors)

**PCPW 235  
MKP**

## Ordering Information

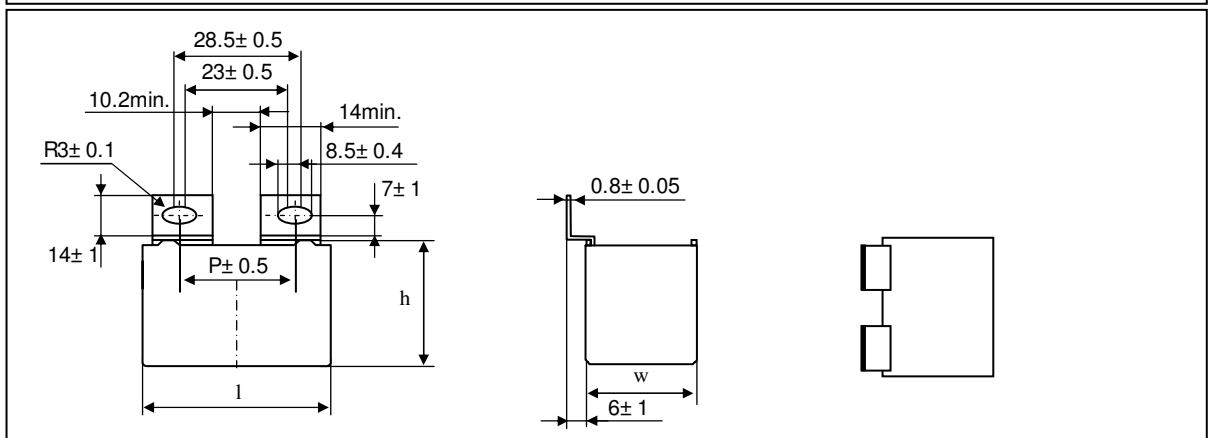
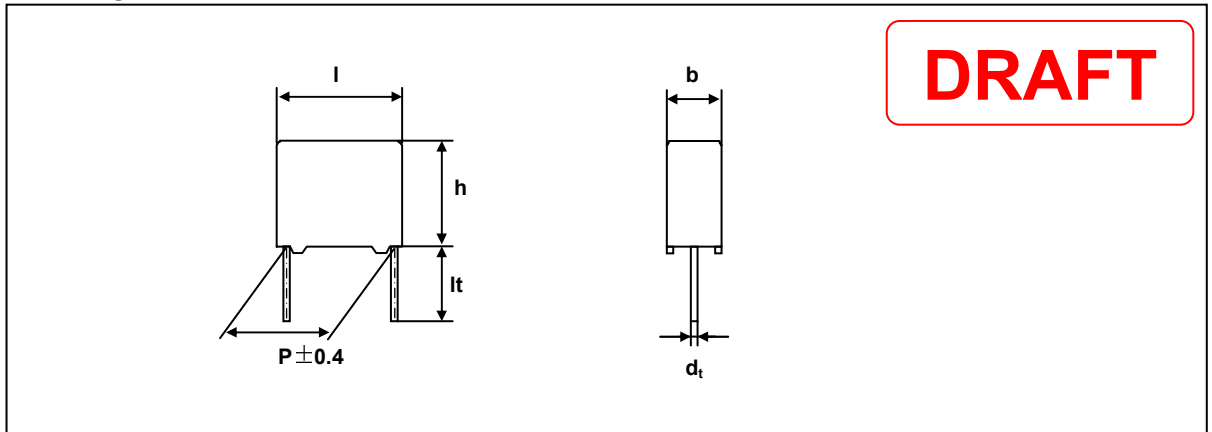

**PCPW 235**

Type series

**X X XXX**

Capacitance

Code	Voltage
X	850 V
X	1000 V
X	1250 V

available versions				Product (I <sub>max</sub> )	
Code	Packing method	C-tol.	Terminal Style	42	42
				Pitch (P)	
X	Loose in box	± 10%	PB	23-28	23-28
X	Loose in box	± 5%	PB	23-28	23-28

# Snubber Capacitor (Metallised Polypropylene Film Capacitors)

## PCPW 235 MKP

# DRAFT

$V_{Rdc} = 850V$        $V_{Rac} = 450V$        $V_{peak} = 1200V$

Cap ( $\mu F$ )	b x h x l (mm)	$d_t$ (mm) or Terminal	P (mm)	dv/dt (V/us)	$I_{peak}$ (A)	$I_{Rms}$ (A)*	ESR (m $\Omega$ )**	Code
								$\pm 10\%$
1.0	28.0 X 37.0 X 42.0	-	23-28	758	758	22	4.0	PCPW 235****
1.5	28.0 X 37.0 X 42.0	-	23-28	758	1138	29	2.7	PCPW 235****
2.0	30.0 X 45.0 X 42.0	-	23-28	758	1668	37	1.9	PCPW 235****

$V_{Rdc} = 1000V$        $V_{Rac} = 480V$        $V_{peak} = 1300V$

Cap ( $\mu F$ )	b x h x l (mm)	$d_t$ (mm) or Terminal	P (mm)	dv/dt (V/us)	$I_{peak}$ (A)	$I_{Rms}$ (A)*	ESR (m $\Omega$ )**	Code
								$\pm 10\%$
1.0	24.0 X 39.0 X 42.0	-	23-28	827	827	23	3.7	PCPW 235****
1.5	28.0 X 37.0 X 42.0	-	23-28	827	1241	23	2.5	PCPW 235****

$V_{Rdc} = 1250V$        $V_{Rac} = 500V$        $V_{peak} = 1600V$

Cap ( $\mu F$ )	b x h x l (mm)	$d_t$ (mm) or Terminal	P (mm)	dv/dt (V/us)	$I_{peak}$ (A)	$I_{Rms}$ (A)*	ESR (m $\Omega$ )**	Code
								$\pm 10\%$
0.47	24.0 X 39.0 X 42.0	-	23-28	965	454	18	6.7	PCPW 235****
0.68	24.0 X 39.0 X 42.0	-	23-28	965	656	21	4.7	PCPW 235****
1.0	28.0 X 37.0 X 42.0	-	23-28	965	965	27	3.3	PCPW 235****

$V_{Rdc} = 1600V$        $V_{Rac} = 500V$        $V_{peak} = 1600V$

Cap ( $\mu F$ )	b x h x l (mm)	$d_t$ (mm) or Terminal	P (mm)	dv/dt (V/us)	$I_{peak}$ (A)	$I_{Rms}$ (A)*	ESR (m $\Omega$ )**	Code
								$\pm 10\%$
0.47	24.0 X 39.0 X 42.0	-	23-28	965	454	18	6.7	PCPW 235****
0.68	28.0 X 37.0 X 42.0	-	23-28	965	656	21	4.7	PCPW 235****

(\*)100kHz@70°C

(\*\*)max@100kHz

# Snubber Capacitor (Metallised Polypropylene Film Capacitors)

PCPW 235  
MKP

## CHARACTERISTICS

**DRAFT**

### ● Test Voltage

- . Test Voltage ( between terminations ) :  $1.5 \times V_{Rdc}$ , 10s ( 1 min for type test )
- . Test Voltage ( between leads and case ) : 3KV- 50Hz(or 60Hz) for 60 seconds

### ● Dissipation Factor

Rated voltage	Capacitance	Tangent of loss angle ( $\times 10^{-4}$ )		
		1 kHz	10 kHz	100 kHz
V	$C \leq 0.1 \mu F$	-	-	$\leq 5$
	$0.1 \mu F < C \leq 1.0 \mu F$	$\leq 5$	$\leq 8$	-
	$1.0 \mu F < C \leq 25 \mu F$	$\leq 5$	$\leq 15$	-

### ● Insulation Resistance

The insulation resistance is measured for 1min  $\pm$ 5s, at 100V  
 $RC (\Omega \cdot F) > 30,000 \text{ s}$

### ● Typical capacitance change versus operating

- 5% after 30,000hrs at  $V_{rms}$  or after 100,000hrs at  $V_{rdc}$

### ● Damp heat test

TEST	CONDITIONS	REQUIREMENTS
Damp heat test ( Steady state )	Temp. = $40 \pm 2 \text{ }^\circ\text{C}$ Relative humidity = $93 \pm 2\%$ Test Duration = 56 days	$\Delta C/C \leq 2\%$ $\Delta \tan \delta < 0.0010$ (@ 1kHz) $R_{ins} \geq 50\%$ specified value

## PRODUCT MARKING

Capacitors are marked on the top or on the top and one side with the following information :

- . Rated capacitance code in accordance with IEC 60062
- . Tolerance on rated capacitance : J :  $\pm 5\%$  K :  $\pm 10\%$
- . Rated (DC) Voltage ( e.g. 400 V )
- . Code for dielectric material (MKP)
- . Manufacturer's type designation ( PCPW235 )
- . Manufacturer's name (PILKOR)

Example of marking

1u0	K	850V	PILKOR
PCPW235	MMKP	WK...	

Marking on the top or side

# Snubber Capacitor (Metallised Polypropylene Film Capacitors)

PCPW 235  
MKP

## TEST REQUIREMENTS

**DRAFT**

No	ITEM	TEST Conditions	REQUIREMENTS												
1	Capacitance	1) Temperature : $25 \pm 2^{\circ}\text{C}$ 2) Frequency : $1\text{kHz} \pm 200\text{Hz}$ 3) Test voltage : $5V_{\text{rms}}$ Max.	Shall be with in prescribed tolerance range												
2	Dissipation factor	1) Temperature : $25 \pm 2^{\circ}\text{C}$ 2) Frequency : $1\text{kHz} \pm 200\text{Hz}$ 3) Test voltage : $5V_{\text{rms}}$ Max.	$\frac{C \leq 5\mu\text{F}}{< 5}$ $\frac{5\mu\text{F} < C \leq 25\mu\text{F}}{< 8}$ $\frac{C > 25\mu\text{F}}{< 10}$												
3	Dielectric strength	Lead-lead : $1.6 \times V_{\text{Rdc}}$ , 1min Lead-case : $3\text{KV}(50\sim 60\text{Hz})$ , 1min	no breakdown, flash over (cut-off current 10mA)												
4	Insulation Resistance	at 100V for $V_{\text{Rdc}} < 500\text{V}$ at 500V for $V_{\text{Rdc}} \geq 500\text{V}$	$\text{RC} (\Omega \cdot \text{F}) > 30,000 \text{ s}$												
5	Damp heat steady state	$40 \pm 2^{\circ}\text{C}$ , 90~95%RH, 56days	$\Delta C/C < \pm 3\%$ at 1KHz $\Delta \text{DF} < 0.0010$ at 1KHz $\text{IR} < 50\%$ of specified limit												
6	Endurance	$85 \pm 2^{\circ}\text{C}$ : $1.25 \times V_{\text{Rdc}}$ , 1000hrs $105 \pm 2^{\circ}\text{C}$ : $1.0 \times V_{\text{Rdc}}$ , 1000hrs	$\Delta C/C < \pm 5\%$ at 1KHz $\Delta \text{DF} < 0.0010$ at 1KHz $\text{IR} < 50\%$ of specified limit												
7	Rapid change of temperature	$-40 \pm 2^{\circ}\text{C}$ = lower category temp. $+105 \pm 2^{\circ}\text{C}$ = upper category temp. Duration $t = 30\text{min}$ Five cycles	Visual : No abnormality $\Delta C/C < \pm 3\%$ at 1KHz $\Delta \text{DF} < 0.0010$ at 1KHz $\text{IR} < 50\%$ of specified limit												
8	Robustness of termination	1) <b>【Lead pull test】</b> <table border="1"> <thead> <tr> <th>Dia.(mm)</th> <th>Load (N)</th> <th>Time (sec)</th> </tr> </thead> <tbody> <tr> <td><math>0.5 &lt; d \leq 1.2</math></td> <td>10</td> <td><math>10 \pm 1(\text{s})</math></td> </tr> </tbody> </table> 2) <b>【Lead bend test(2cycle)】</b> <table border="1"> <thead> <tr> <th>Dia.(mm)</th> <th>Load (N)</th> <th>Time (sec)</th> </tr> </thead> <tbody> <tr> <td><math>0.5 &lt; d \leq 1.2</math></td> <td>5</td> <td><math>0.51(\text{s})</math></td> </tr> </tbody> </table>	Dia.(mm)	Load (N)	Time (sec)	$0.5 < d \leq 1.2$	10	$10 \pm 1(\text{s})$	Dia.(mm)	Load (N)	Time (sec)	$0.5 < d \leq 1.2$	5	$0.51(\text{s})$	No abnormality such as cutting, slack of termination
Dia.(mm)	Load (N)	Time (sec)													
$0.5 < d \leq 1.2$	10	$10 \pm 1(\text{s})$													
Dia.(mm)	Load (N)	Time (sec)													
$0.5 < d \leq 1.2$	5	$0.51(\text{s})$													
9	Solderability	Non-activated colophony flux 501 Solder bath temp. : $245 \pm 5^{\circ}\text{C}$ Immerse time : $2 \pm 0.5\text{s}$	Good tinning as evidenced by free flowing of the solder with wetting of the terminations (>95%)												
10	Resistance to soldering heat	Solder bath temp. : $260 \pm 5^{\circ}\text{C}$ Immerse time : $10 \pm 0.5\text{s}$	Visual : No abnormality $\Delta C/C < \pm 3\%$ at 1KHz $\Delta \text{DF} < 0.0010$ at 1KHz $\text{IR} < 50\%$ of specified limit												
11	Vibration	10Hz to 55Hz Amplitude : $0.75\text{mm}$ or acceleration $98\text{m/s}^2$ 6hrs	Visual : No abnormality $\Delta C/C < \pm 3\%$ at 1KHz $\Delta \text{DF} < 0.0010$ at 1KHz $\text{IR} < 50\%$ of specified limit												

TENTATIVE TARGET SPECIFICATION

5 OF 6