

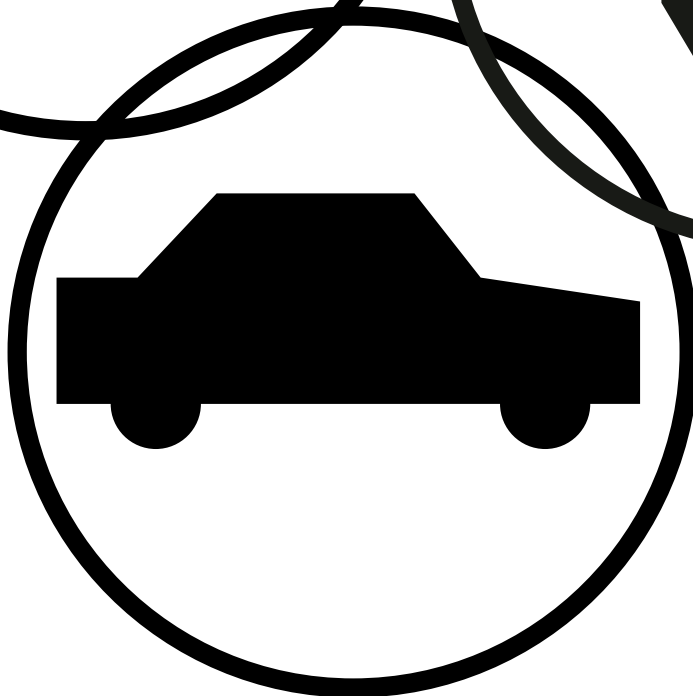

**WORLD PRODUCTS INC.**  
ELECTRONIC COMPONENT SOLUTIONS



# LC FILTERS



## Features

1. Newly developed for prominent EMI attenuation at high speed signal lines.
2. Terminal electrode has excellent solder heat resistance for soldering.
3. RoHS compliant with Directive 2002/95/EC of the European Parliament and of the Council of 27 January 2003 on the restriction of the use of certain hazardous substances in electrical and electronic equipment (RoHS Directive) and comply to a maximum concentration value of 0.1% by weight in homogeneous materials for lead (Pb), mercury, hexavalent chromium, polybrominated biphenyls (PBB) and polybrominated diphenyl ethers (PBDE) and of 0.01% weight in homogeneous materials for cadmium.

## Applications

1. High resolution video signal lines.
2. EMI countermeasure for clock signal lines.

## Ordering Information

**WPL** - **2012** - **300** **I**  
(1) (2) (3) (4)

**(1) Series**

**WPL:** LC Filters

**(2) Dimensions \***

The first two digits: length (mm)

The last two digits: width (mm)

**(3) Cut-off frequency**

First two digits are significant.

Last digit is the number of zeros following.

**(4) Packaging**

**B:** Bulk Package

**T:** Tape & Reel ( $\Phi$  178mm [ 7 inch ])

**L:** Tape & Reel ( $\Phi$  254mm [10 inch ])

\*2012(mm) is equivalent to 0805 (inches).

## Shape & Dimensions

Unit : mm [inches]

Type	L	W	T	C <sub>1</sub>	C <sub>2</sub>
WPL-2012	2.0 ± 0.2 [.079 ± .008]	1.25 ± 0.2 [.049 ± .008]	0.8 ± 0.2 [.031 ± .008]	0.30 ± 0.20 [.012 ± .008]	0.4 ± 0.2 [.016 ± .008]

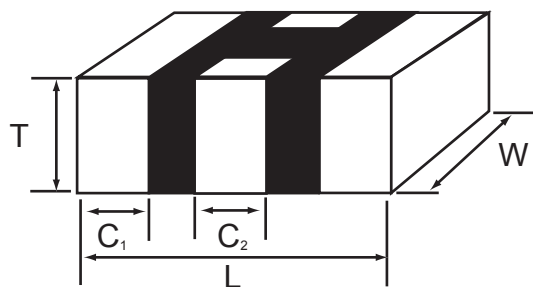

# LC FILTERS

## Specifications

2012 SERIES

Part No.	Cut-off Frequency	20dB Attenuation Frequency range	DC Resistance	Rated Current	Rated Voltage
WPL-2012-300□	30MHz	65-2500MHz	800mΩ max.	300mA max.	10Vdc max.
WPL-2012-500□	50MHz	90-2500MHz			
WPL-2012-101□	100MHz	210-2500MHz			
WPL-2012-151□	150MHz	350-2500MHz			

## Attenuation vs. Frequency Characteristics

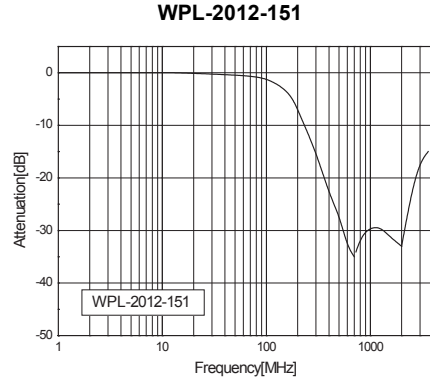
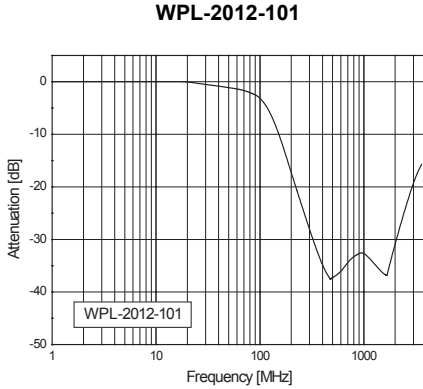
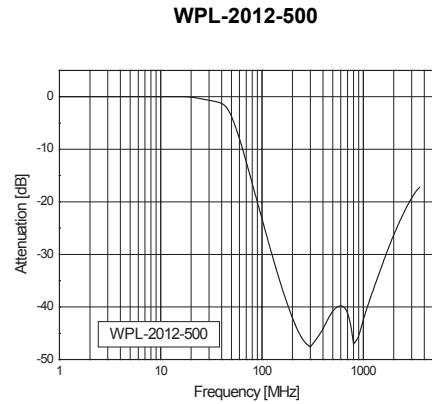
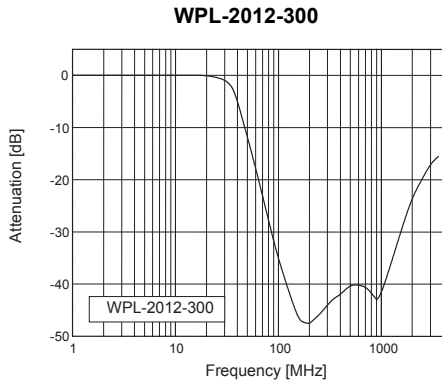

## Attenuation Measuring Circuit

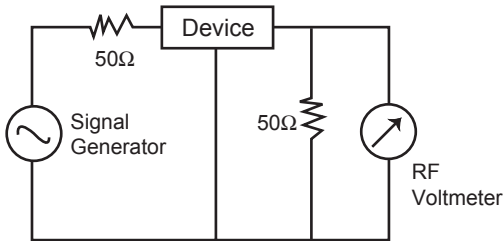

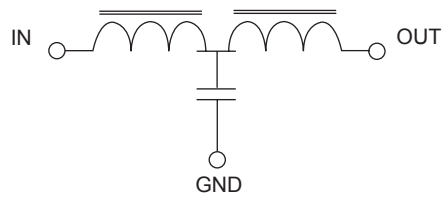

## Equivalent Circuit

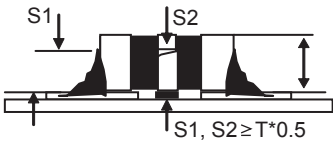

The WPL Series has no polarity.

## Reliability and Test Conditions

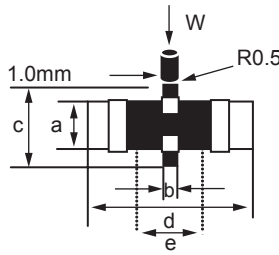
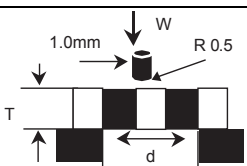
ITEM	REQUIREMENTS		TEST CONDITION
	2012		
Operating temp.range	-55°C~+125°C		-
Storage temp. & humidity range	40°C max. , 70% RH max.		at packing condition
Resistance to solder heat	1. No damage such as cracks should be caused in chip element. 2. More than 75% of the terminal electrode shall be covered with new solder. 3. Inductance change : $\pm$ within 5% 4. Capacitance change : $\pm$ within 30%		Preheat temperature: 100 to 150°C Preheat time: 1min Solder temperature: 260 $\pm$ 10°C Dipping time: 10 $\pm$ 0.5sec.
Solderability	1. More than 90% of the terminal electrode shall be covered with new solder. 2. Inductance change : $\pm$ within 5% 3. Capacitance change : $\pm$ within 30%		Preheat temperature: 100 to 150°C Preheat time: 1min Solder temperature: 230 $\pm$ 10°C Dipping time: 3 $\pm$ 1sec.
Reflow soldering	1. More than 50% of the terminal electrode shall be covered with new solder. 		Preheat temperature: 150°C Preheat time: 1min Solder temperature: 230°C Soldering time: 10 sec. Max. (Reflow soldering profile)
Tensile strength (Terminal strength)	1. No mechanical damage.  Unit: Kgf(W)		
	W	2.0	
Adhesion of Terminal electrode (Flexure strength)	1. No mechanical damage.  Unit: mm (a,b,c,d,e), Kgf(W)		
	a	1.0	
	b	0.4	
	c	2.0	
	d	3.0	
	e	1.4	
	W	4.0	
Body strength (Bending strength)	1. The body shall not be damaged by forces applied (see illustration.)  Unit: mm (d), Kgf(W)		
	d	1.3	
	W	3.0	

# LC FILTERS

## Reliability and Test Conditions

ITEM	REQUIREMENTS		TEST CONDITION
	2012		
Drop	1. No mechanical damage.		Drop 10 times on a concrete Floor from a height of 91cm.
Vibration	1. No mechanical damage.		Frequency: 10~55~10Hz Amplitude: 1.52mm Direction and time: X,Y,Z directions for 1 hour
Thermal shock (Temperature cycle)	1. No mechanical damage. 2. Inductance change: $\pm$ within 5% 3. Capacitance change: $\pm$ within 30% 4. Insulation resistance (between 1 and 2): 100M $\Omega$ min.		Step1. $-40 \pm 3^{\circ}\text{C}$ , 30 $\pm$ 3min. Step2. $85 \pm 3^{\circ}\text{C}$ , 30 $\pm$ 3min. Number of cycles: 100 times
Heat load resistance	1. No mechanical damage. 2. Inductance change: $\pm$ within 5% 3. Capacitance change: $\pm$ within 30% 4. Insulation resistance (between 1 and 2): 100M $\Omega$ min.		Temperature: $85 \pm 2^{\circ}\text{C}$ Applied voltage: rated voltage (between 1 and 2) Applied current: rated current (between 1 and 3) Time: 1,000 hours Measured at ambient temperature after placing for 24 hours
Low temp. resistance	1. No mechanical damage. 2. Inductance change: $\pm$ within 5% 3. Capacitance change: $\pm$ within 30% 4. Insulation resistance (between 1 and 2): 100M $\Omega$ min.		Temperature: $-40 \pm 5^{\circ}\text{C}$ Time: 1,000 hours Measured at room ambient temperature after placing for 24 hours
Humidity resistance	1. No mechanical damage 2. Inductance change : $\pm$ within 5% 3. Capacitance change: $\pm$ within 30% 4. Insulation resistance (between 1 and 2): 100M $\Omega$ min.		Temperature: $40 \pm 2^{\circ}\text{C}$ Humidity: 90~95% RH Time: 500 hours Measured at ambient temperature after placing for 24 hours
Humidity load resistance	1. No mechanical damage 2. Inductance change : $\pm$ within 5% 3. Capacitance change: $\pm$ within 30% 4. Insulation resistance (between 1 and 2): 100M $\Omega$ min.		Temperature: $85 \pm 2^{\circ}\text{C}$ Applied voltage: rated voltage (between 1 and 2) Applied current: rated current (between 1 and 3) Time: 1000 hours Measured at room ambient temperature after placing for 24 hours

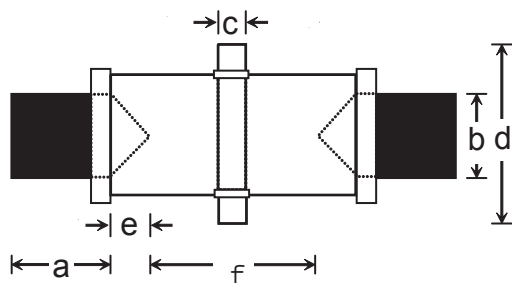
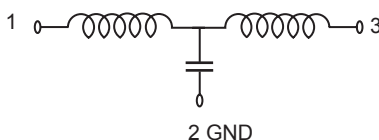

unit: mm

Size	a	b	c	d	e	f
2012	1.0	1.0	0.4	2.0	0.1	1.4

## Labeling

### Label

- 1) Part name.
- 2) Lot No.
- 3) Quantity.

### Standard quantity for packing (pcs)

Packing Type(EIA)	Tape & reel			Bulk
	Reel	Inner box	Carton box	Vinyl or Cassette
2012	3,000	30,000	120,000	As requested
	7,000	70,000	280,000	

\*Packing method can be changed upon request.

## Tape Dimensions

### Embossing 8mm

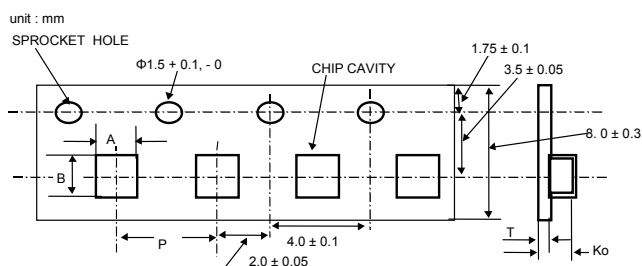

unit: mm

Type	A ± 0.1	B ± 0.1	P ± 0.1	Ko ± 0.1	T (max.)
2012	1.45	2.25	4.0	1.00	0.3

## Leader and Blank Portion

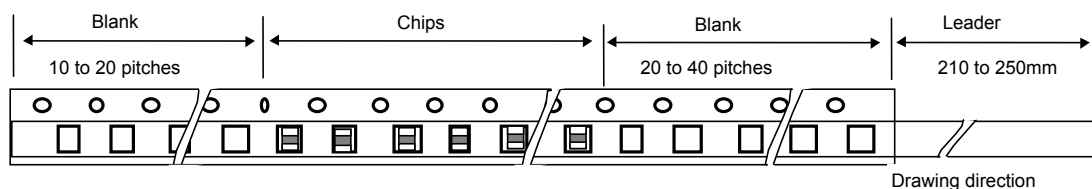

The pitch holes shift within  $\pm 0.3\text{mm}$  for cumulative 10 pitches.

## Reel Dimensions

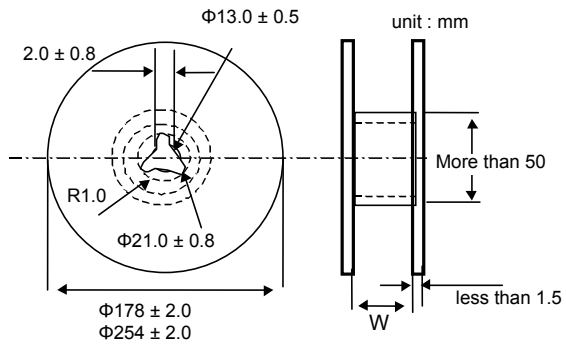

Type	W (mm)
2012	$9.0 \pm 0.3$

## Top Cover Tape Strength

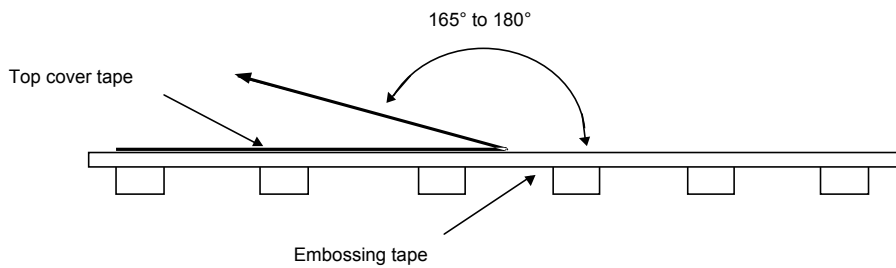

The force for tearing off top cover tape is 20 to 70 grams in the arrow direction.

## Soldering Profile

### REFLOW SOLDERING(Peak 230°C)

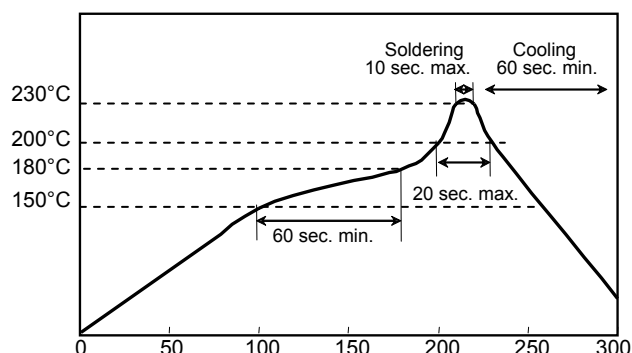

### REFLOW SOLDERING (Peak 250°C)

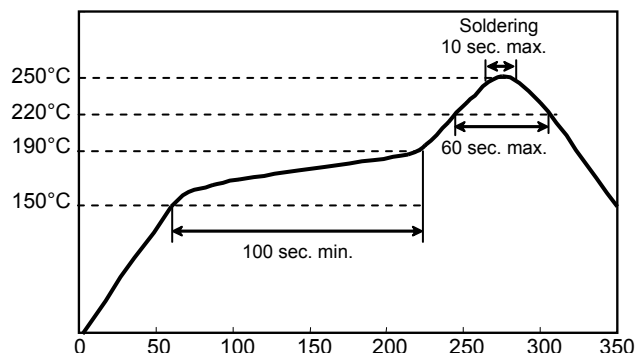

### FLOW SOLDERING

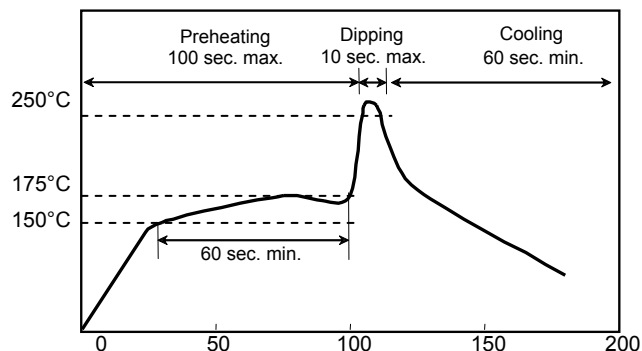

### MANUAL SOLDERING

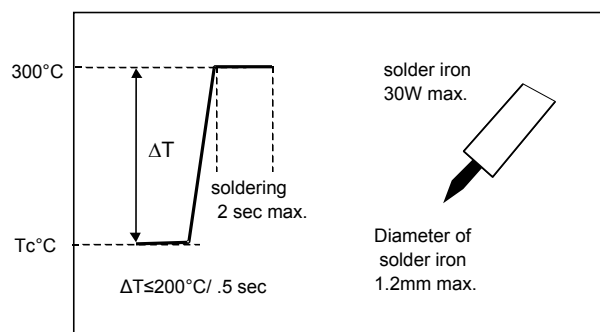

## Precaution for Product Storage

Electrical characteristics of product will not change when stored under typical environmental conditions. However, it is possible that the solderability of the terminal electrodes and the characteristics of the tape packaging can change during storage. For this reasons, the following storage guidelines should be followed.

**STORAGE ENVIRONMENT** The tape packaging material is designed to withstand long-term storage but it may degrade more rapidly in the presence of high temperature or high humidity. Therefore, product shall be stored in an ambient temperature of less than 40°C with a relative humidity of less than 70%. The products should be used within 6 months of receipt.

To achieve best solderability, product should be used as soon as possible after unpacking. Leftover product must be stored in dry condition with desiccant.

**CORROSIVE GASES** Since sulfur and chlorine may degrade the solderability of the terminal electrodes, it is important to store the product in an environment free of such gases.

**TEMPERATURE FLUCTUATIONS** Dew condensation may occur when the product is taken out of storage due to variation of temperature. It is important to maintain a temperature-controlled environment.

**DISCLAIMER:** The names of the products and the specifications in this catalog are subject to change without notice for the sake of improvement. World Products Inc. also reserves the right to discontinue any of these products. The products in this catalog are intended for use in ordinary electronic products. If any of these products are to be used in special applications requiring extremely high reliability, where product defects might pose a safety risk, please consult World Products Inc. Though World Products Inc. has taken all possible precautions to ensure the quality and reliability of its products, improper use of products may result in bodily injury, fire, or similar accident. If you have any questions regarding the use of the products in question, please consult World Products Inc. Please be advised that World Products Inc. accepts no responsibility for any infraction by users of World Products Inc. products on third party patents or industrial copyrights.