

Features

1. Normally open, single pole single throw.
2. Control 200VAC or DC voltage.
3. Switch 180mA loads.
4. LED control current, 5mA.
5. Low ON-resistance.
6. dv/dt , >500V/mS.
7. Isolation test voltage, 1500VRMS.
8. Package Type: SOP (shown)

Part Numbering System & Part Marking System: Page 3 & 4.

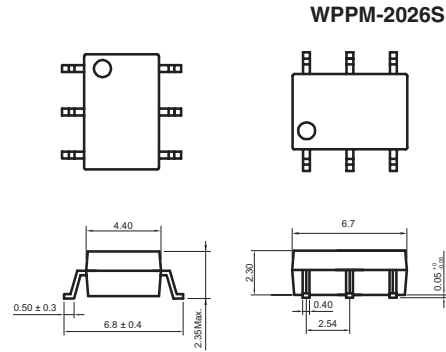

Absolute Maximum Ratings

(Ta = 25°C)

Emitter (Input)	Detector(Output)
Reverse Voltage.....5.0V	Output Breakdown Voltage±200V
Continuous Forward Current50mA	Continuous Load Current±180mA
Peak Forward Current1A	Power Dissipation450mW
Power Dissipation75mW	
Derate Linearly from 25°C1.3mW/°C	
General Characteristics	
Isolation Test Voltage 1500VRMS	Storage Temperature Range ...-40°C to +150°C
Isolation Resistance, V _{IO} = 500V, T _A = 25°C.....>10 ¹⁰ Ω	Operating Temperature Range ..-40°C to +85°C
	Junction Temperature 100°C
Total Power Dissipation500mW	Soldering Temperature,
Derate Linearly from 25°C2.5mW/°C	2mm from case, 10 sec.260°C

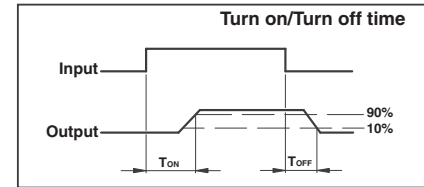

Electro-optical Characteristics

(Ta = 25°C)

Parameter	Symbol	Conditions	Min.	Typ.	Max.	Unit	
<i>Emitter (Input)</i>							
Forward Voltage	V _F	I _F = 10mA	-	1.2	1.5	V	
Operation Input Current	I _{FON}	V _L = ±20V, I _L = 100mA, t = mS	-	-	5	mA	
Recovery Input Current	I _{FOFF}	V _L = ±20V, I _L = <5uA	0.2	-	-	mA	
<i>Detector(output)</i>							
Output Breakdown Voltage	V _B	I _B = 50uA	200	-	-	V	
Output Off-State Leakage	I _{TOFF}	V _T = 100V, I _F = 0mA	-	0.2	1	uA	
I/O Capacitance	C _{ISO}	I _F = 0, f = 1MHz	-	6	-	pF	
ON Resistance	Connection	A	I _L = 100mA, I _F = 10mA	-	6	15	Ω
		B		-	3	8	
		C		-	1.5	4	
Turn-On Time	T _{ON}	I _F = 10mA, V _L = ±20V	-	0.4	1.0	mS	
Turn-Off Time	T _{OFF}	t = 10mS, I _L = ±100mA	-	0.3	1.0	mS	

MOS Relay Schematic and Wiring Diagrams

Type	Schematic	Output Configuration	Load	Connection	Wiring Diagrams
2026S		1a	AC/DC	A	
			DC	B	
			DC	C	

Data Curves

