

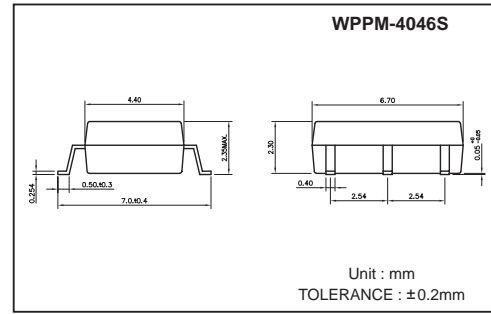

USR/CNR Listed (File # 223388)

## Features

1. Normally closed, single pole single throw.
2. Control 400VAC or DC voltage.
3. Switch 130mA loads.
4. LED control current, 5mA.
5. Low ON-resistance.
6. dv/dt, >500V/mS.
7. Isolation test voltage, 1500V<sub>RMS</sub>.
8. Package Type: SOP (shown)



Part Numbering System & Part Marking System: Page 3 & 4

## Absolute Maximum Ratings

(Ta=25°C)

Emitter ( Input )		Detector ( Output )	
Reverse Voltage.....	5.0V	Output Breakdown Voltage .....	±400V
Continuous Forward Current .....	50mA	Continuous Load Current .....	±130mA
Peak Forward Current .....	1A	Power Dissipation .....	500mW
Power Dissipation .....	100mW		
Derate Linearly from 25°C .....	1.3mW/°C		
General Characteristics			
Isolation Test Voltage .....	1500V <sub>RMS</sub>	Storage Temperature Range ...	-40°C to +125°C
Isolation Resistance		Operating Temperature Range ...	-30°C to +85°C
V <sub>IO</sub> = 500V, T <sub>A</sub> = 25°C .....	≥10 <sup>10</sup> Ω	Junction Temperature.....	100°C
Total Power Dissipation .....	550mW	Soldering Temperature,	
Derate Linearly from 25°C .....	2.5mW/°C	2mm from case, 10 sec .....	260°C

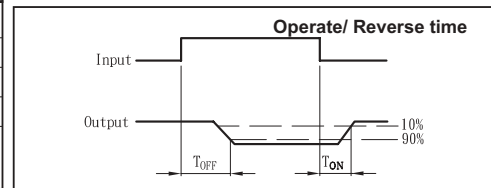

## Electro-optical Characteristics

(Ta=25°C)

Parameter	Symbol	Conditions	Min.	Typ.	Max.	Unit
Emitter (Input)						
Forward Voltage	V <sub>F</sub>	I <sub>F</sub> = 10mA		1.2	1.5	V
Operation Input Current	I <sub>FOFF</sub>	V <sub>L</sub> = ±20V, I <sub>L</sub> ≤ 5uA			5	mA
Recovery Input Current	I <sub>FON</sub>	V <sub>L</sub> = ±20V, I <sub>L</sub> = 100mA, t = 10mS	0.2			mA
Detector (Output)						
Output Breakdown Voltage	V <sub>B</sub>	I <sub>B</sub> = 50uA	400			V
Output Off-State Leakage	I <sub>TOFF</sub>	V <sub>T</sub> = 100V, I <sub>F</sub> = 0mA		0.2	2	uA
I/O Capacitance	C <sub>ISO</sub>	I <sub>F</sub> = 0, f = 1MHz		6		pF
ON Resistance	Connection	A	I <sub>L</sub> = 100mA, I <sub>F</sub> = 10mA	40	50	Ω
		B		20	25	
		C		10	12.5	
Reverse (NO) Time	T <sub>ON</sub>	I <sub>F</sub> = 10mA, V <sub>L</sub> = ±20V		0.6	1.5	mS
Operate (OFF) Time	T <sub>OFF</sub>	t = 10mS, I <sub>L</sub> = ±100mA		0.3	1.0	mS

## MOS Relay Schematic and Wiring Diagrams

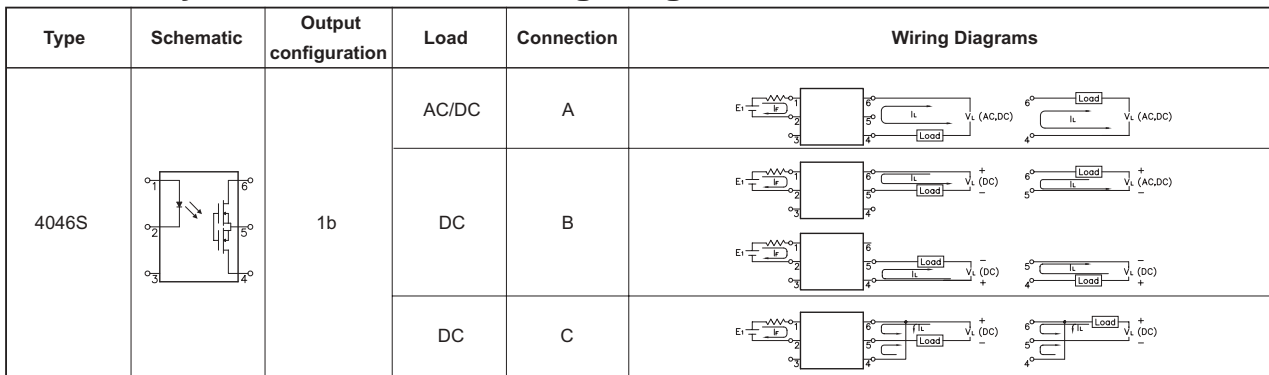

**Data Curve**

