

# PART NUMBERING SYSTEM

## ISOMOS™ PHOTO MOS RELAY

### STANDARD & SOP

Example part number:

WPPM - 35 2 8 S - TRU  
(1) (2) (3) (4) (5) (6)

**(1) Photo MOS**

**(2) Load Voltage**

06: 60V  
10: 100V  
20: 200V  
35: 350V  
40: 400V

**(3) Contact Characteristics**

2: 1 Form A  
4: 1 Form B  
6: 1 Form A + 1 Form B  
8: Dual Form A  
10: Dual Form B

**(4) Pin Configuration**

4: 4 pin  
6: 6 pin  
8: 8 pin  
16: 16 pin

**(5) Package Types**

D: DIP  
A: SMD  
S: SOP

**(6) Taping**

TLD: Tape Direction Left  
TRU: Tape Direction Right

### CUSTOM VERSIONS

Example part number:

WPPML - 35 2 4 S - TRU  
(1) (2) (3) (4) (5) (6)

**(1) Photo MOS Custom**

**(2) Load Voltage**

35: 350V  
06: 60V (only available in SOP package)

**(3) Contact Characteristics**

2: 1 Form A

**(4) Pin Configuration**

4: 4 pin

**(5) Package Types**

D: DIP  
A: SMD  
S: SOP

**(6) Taping**

TLD: Tape Direction Left  
TRU: Tape Direction Right

Not all combinations are available

# PART MARKING SYSTEM

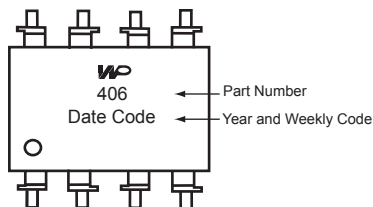



**Features**

1. Normally open and close, single pole single throw.
2. Control 400VAC or DC voltage.
3. Switch 130mA loads.
4. LED control current, 5mA.
5. Low ON-resistance.
6. dv/dt, >500V/mS.
7. Isolation test voltage, 3750V<sub>RMS</sub>.

**Part Numbering System:** Page 1 **Part Marking System:** Page 1

**Absolute Maximum Ratings**

(Ta=25°C)

<b>Emitter ( Input )</b>	
Reverse Voltage .....	5.0V
Continuous Forward Current .....	50mA
Peak Forward Current .....	1A
Power Dissipation .....	100mW
Derate Linearly from 25°C .....	1.3mW/°C
<b>Detector ( Output )</b>	
Output Breakdown Voltage .....	±400V
Continuous Load Current .....	±130mA
Power Dissipation .....	500mW
<b>General Characteristics</b>	
Isolation Test Voltage .....	3750V <sub>RMS</sub>
Isolation Resistance V <sub>IO</sub> = 500V, T <sub>A</sub> = 25°C .....	≥10 <sup>10</sup> Ω
Total Power Dissipation .....	550mW
Derate Linearly from 25°C .....	2.5mW/°C
Storage Temperature Range .....	-40°C to +125°C
Operating Temperature Range .....	-30°C to +85°C
Junction Temperature .....	100°C
Soldering Temperature, 2mm from case, 10 sec .....	260°C

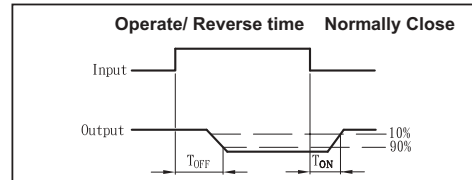
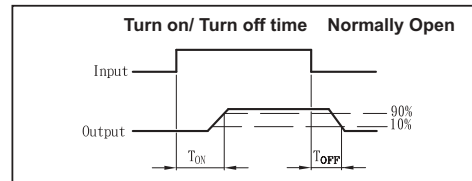
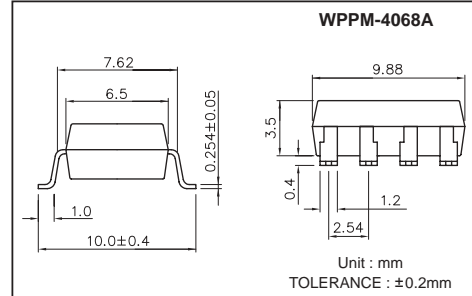
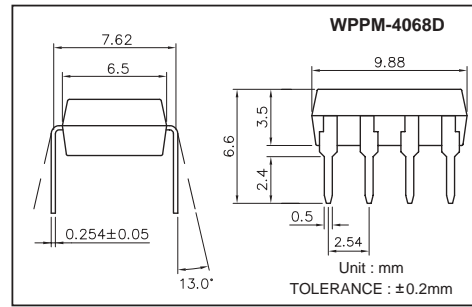



## Electro-optical Characteristics

(Ta=25°C)

Parameter	Symbol	Conditions	Min.	Typ.	Max.	Unit
Emitter (Input)						
Forward Voltage	V <sub>F</sub>	I <sub>F</sub> = 10mA		1.2	1.5	V
Operation Input Current	I <sub>FON(N.O)</sub> I <sub>FON(N.C)</sub>	V <sub>L</sub> = ±20V, I <sub>L</sub> = 100mA (N.O) V <sub>L</sub> = ±20V, I <sub>L</sub> ≤ 5uA (N.C) t = 10mS			5	mA
Recovery Input Current	I <sub>FON(N.O)</sub> I <sub>FON(N.C)</sub>	V <sub>L</sub> = ±20V, I <sub>L</sub> ≤ 5uA (N.O) V <sub>L</sub> = ±20V, I <sub>L</sub> = 100mA (N.C) t = 10mS	0.2			mA

Detector (Output) normally open						
Output Breakdown Voltage	V <sub>B</sub>	I <sub>B</sub> = 50uA	400			V
Output Off-State Leakage	I <sub>TOFF</sub>	V <sub>T</sub> = 100V, I <sub>F</sub> = 0mA		0.2	1	uA
I/O Capacitance	C <sub>ISO</sub>	I <sub>F</sub> = 0, f = 1MHz		6		pF
ON Resistance	R <sub>ON</sub>	I <sub>L</sub> = 100mA, I <sub>F</sub> = 10mA		20	30	Ω
Turn-On Time	T <sub>ON</sub>	I <sub>F</sub> = 10mA, V <sub>L</sub> = ±20V		0.3	1.0	mS
Turn-Off Time	T <sub>OFF</sub>	t = 10mS, I <sub>L</sub> = ±100mA		0.7	1.5	mS

Detector (Output) normally close						
Output Breakdown Voltage	V <sub>B</sub>	I <sub>B</sub> = 50uA	400			V
Output Off-State Leakage	I <sub>TOFF</sub>	V <sub>T</sub> = 100V, I <sub>F</sub> = 0mA		0.2	2	uA
I/O Capacitance	C <sub>ISO</sub>	I <sub>F</sub> = 0, f = 1MHz		6		pF
ON Resistance	R <sub>ON</sub>	I <sub>L</sub> = 100mA, I <sub>F</sub> = 10mA		40	50	Ω
Reverse (ON) Time	T <sub>ON</sub>	I <sub>F</sub> = 10mA, V <sub>L</sub> = ±20V		0.6	1.5	mS
Operate (OFF) Time	T <sub>OFF</sub>	t = 10mS, I <sub>L</sub> = ±100mA		0.3	1.0	mS

## MOS Relay Schematic and Wiring Diagrams

Type	Schematic	Output configuration	Load	Connection	Wiring Diagrams
4068D & 4068A		1a1b	AC/DC	-	<p>(1) Two independent 1 Form A &amp; 1 Form B use</p> <p>(2) 1 Form A &amp; 1 Form B use</p>



**Data Curve** (WPPM-4068D & WPPM-4068A Normally Open Characteristics)

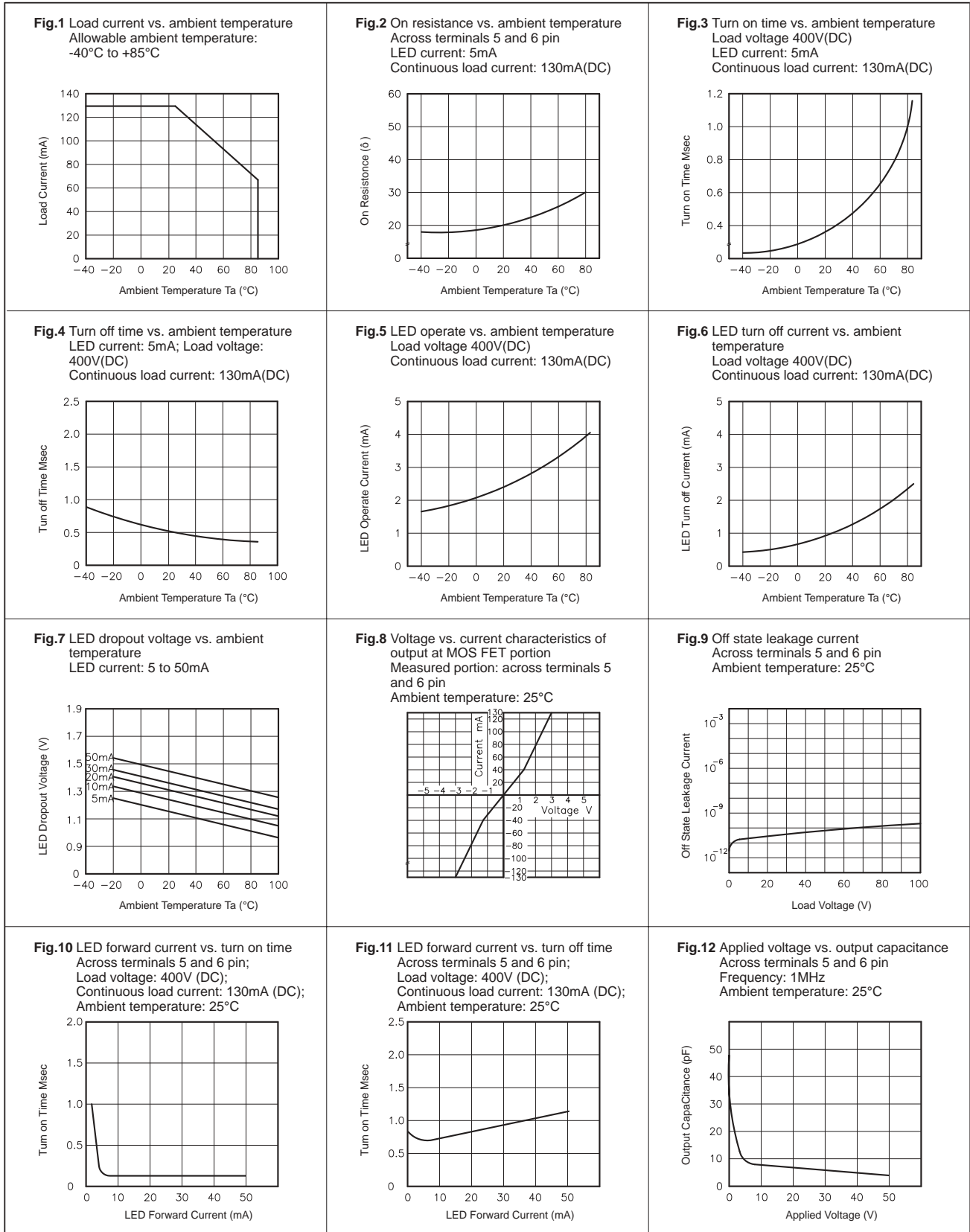

**Data Curve** (WPPM-4068D & WPPM-4068A Normally Closed Characteristics)

